

CRD - 50 Series

Detail

- UL Classified
- For use in non-combustible installations 3 hours or less
- 22 gauge one piece frame
- 165°F fusible link (optional 212°F)
- Standard link (SL) or Easy Access (EA) option
- Available in stainless steel
- Ceramic thermal blanket provided on units with blade areas of greater than 84 sq. in.
- Available in single-section sizes from 4" x 6" or 6" x 4" to 24" x 24"



CONTACT

Office: 888.973.7600

1100 Ashwood Drive
Suite 1102
Canonsburg, PA 15317

www.clward.com

Profile

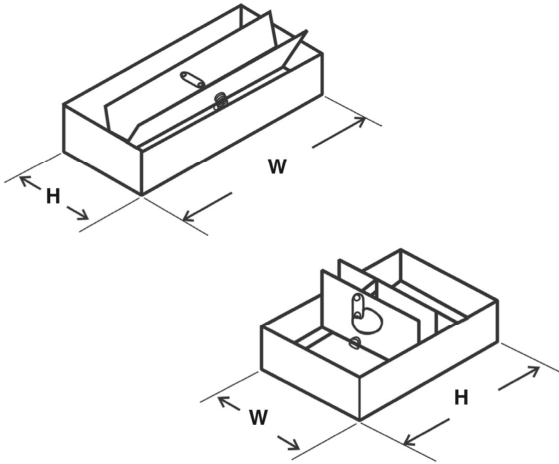

This product meets the requirements for ceiling dampers established by:

UL Standard 555C
NFPA Standard 90A
ICC Building Codes

Item Code Format

5	0	E	A	1	2	1	2	G
---	---	---	---	---	---	---	---	---

SERIES:

CRD
50, 51, 55, 57, 58

LINK:

SL = Standard Link
EA = Easy Access Link

Damper Width

Damper Height

G = Galvanized
165° Link
H = Galvanized
212° Link
S = Stainless Steel
165° Link
T = Stainless Steel
212° Link



Manufactured by:



Job Name	
Location	
Architect	
Engineer	
Contractor	