

Fire Damper - 05 Series, Type A

Detail

- UL Classified - 3 Hour Rating, Static
- For use in installations rated 3 hours or greater
- Standard Profile (4 1/4") 22 gauge frame
- Type A - Blades in the air stream
- Available for vertical and horizontal installations
- 165°F fusible link (optional 212°F)
- Available in stainless steel
- Vertical dampers are available in single-section sizes from 4" x 4" to 60" x 60", multi section sizes to 120" x 120"
- Horizontal dampers are available in single-section sizes from 4" x 4" to 40" x 60", multiple sizes 120" x 60" or 80" x 96"
- Optional 22 gauge sleeve available: 8", 12", 17", 20" or 24"



CONTACT

Office: 888.973.7600

1100 Ashwood Drive
Suite 1102
Canonsburg, PA 15317

www.clward.com

Profile

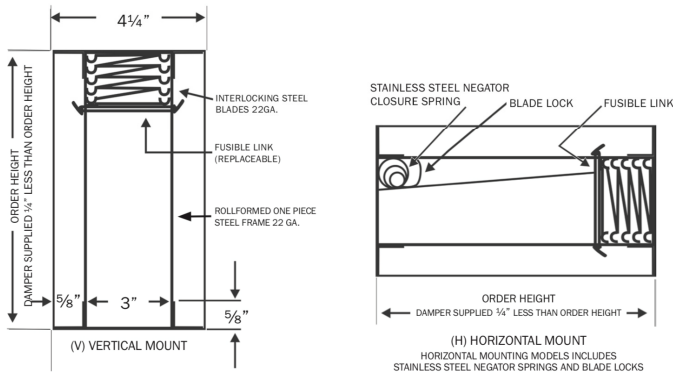

This product meets the requirements for fire dampers established by:

UL Standards 555
NFPA Standard 90A
ICC Building Codes

Item Code Format

0	5	A	H	0	1	2	0	1	2	G	2	2	1	2
---	---	---	---	---	---	---	---	---	---	---	---	---	---	---

SERIES:
Fire Damper
75, 65, 05, 95, 77, 99, 61

TYPE:
Fire Damper
A, B, C (round),
R (rectangular), O (oval)

H = Horizontal
V = Vertical

Damper Width

Damper Height

G = Galvanized
165° Link
H = Galvanized
212° Link
S = Stainless Steel
165° Link
T = Stainless Steel
212° Link

Optional Sleeve
22 = 22 Gauge

Sleeve Length
08 = 8"
12 = 12"
17 = 17"
20 = 20"
24 = 24"



Manufactured by:



Job Name	
Location	
Architect	
Engineer	
Contractor	